

A			
Pos.	Locking torque [Nm]	Loctite 242 100.164	Multit-purpose grease 130.905
3	1.8		
16	6.3	X	
17	1.5		
21	8.0	X	
27	6.3		
30	12.2		
32	1.8	X	
35	3.1	X	
63	-		X
67	1.0	X	
81	1.5	X	
82	-		X
90	1.8		
93	5.7		
109	6.6	X	
112	1.5		
114	2.5	X	
115	flush fit		
122	2.0	X	
128	1.3		
129	1.3		
132	1.3	X	
133	2.9	X	
136	8.0		
140	8.0		
145	1.8		
150	8.0	X	

B			
60			
61			
62			
63			
64			
65			
66			
67			
68			
69			
70			
75			
90			
91			
92			
93			
94			
95			
96			
97			
98			
99			
100			
101			
102			
103			
104			
105			
106			
107			
108			
109			
110			
111			
112			
113			
114			
115			
116			
117			
118			
119			
120			
121			
122			
123			
124			
125			
126			
127			
128			
129			
130			
131			
132			
133			
134			
135			
136			
137			
138			
139			
140			
141			
142			
143			
144			
145			
146			
147			
148			
149			
150			

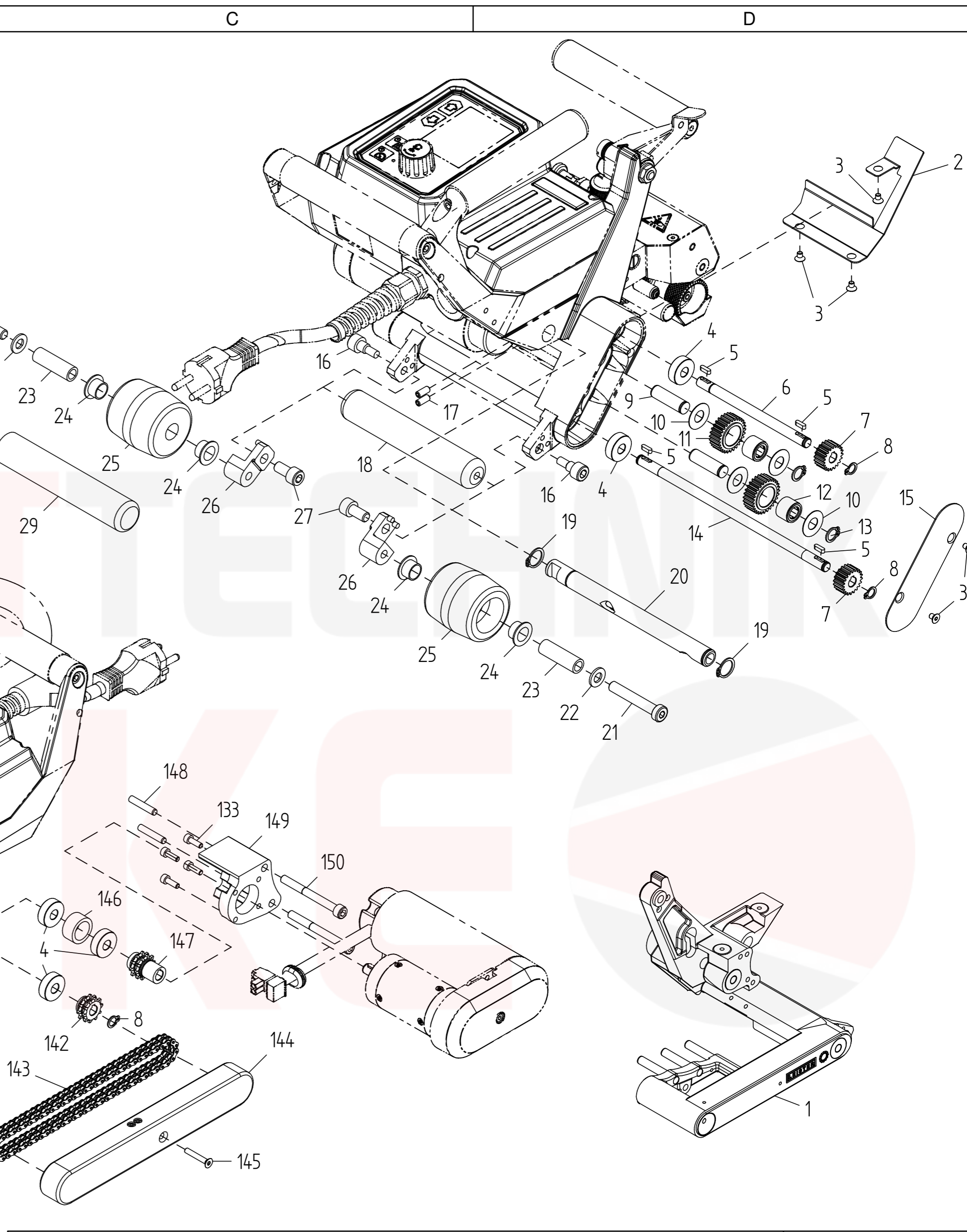
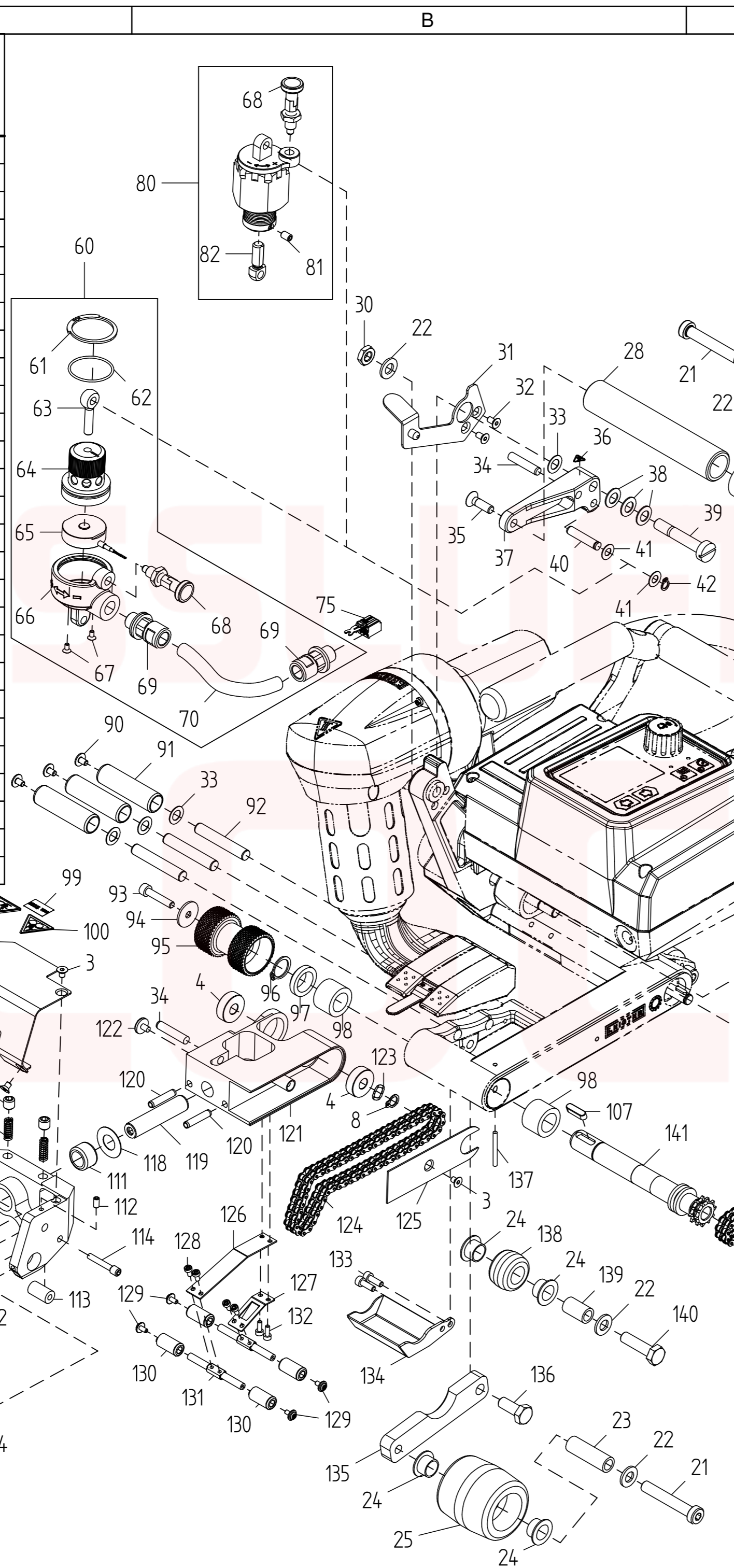

Material: -		Volume:	
Date	Drawn by	<b>Mechanics TWINNY T7/T5</b>	
30.06.20	Sigrist, Flavio		
Date	Checked by		
01.07.20	Gisler, Lukas	Sheet	
Leister Technologies AG Switzerland		Format	Scale
		A3	1:4
		Drawing number	Revision
		<b>020.867</b>	<b>B</b>

This document and the information in it contained are property of LEISTER and as such, they are to be considered reserved.  
 © Therefore, any reproduction in any form or by any means, without prior written permission of LEISTER is forbidden.