

A

B

C

D

1

2

3

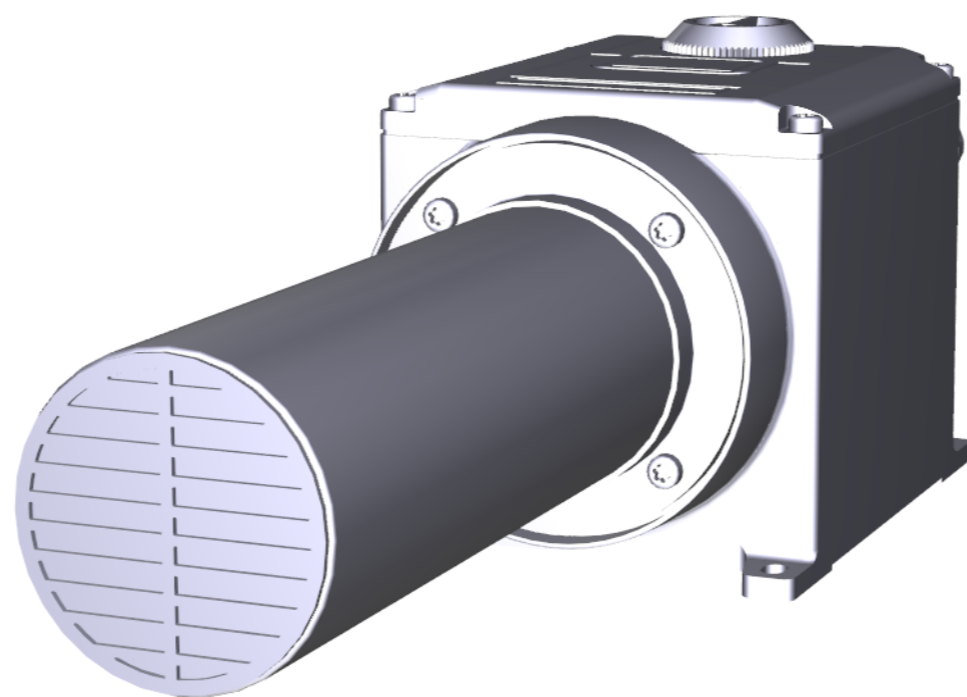

LHS SYSTEM 41L

Format	Scale
A3	%

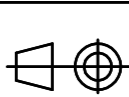

Note:
The information contained in this document is subject to change without notice.
Änderungen vorbehalten.

Sheet	1
of	1
Revision	A

This document and the information in it contained are property of LEISTER and as such, they are to be considered reserved.
 © Therefore, any reproduction in any form or by any means, without prior written permission of LEISTER is forbidden.